

F8 LINE INTERRUPT SWITCH

F8 line interrupt switch

Line interrupt panel mount pushbutton

- Snap-in mounting with long overtravel
- Choice of button barrier or standard housing
- 3 terminal types available
- Double make/double break shorting bars
- Agency approved extended-life versions available
- EN approval
- 3 mm (0.1") minimum contact gap
- Wide range of versions available



Technical specifications

Series	F8 1
Electrical	
Ambient temperature	-25° to +85°C
Flammability rating	UL94V-O
Materials	
Housing	Thermoplastic polyester
Actuator	Thermoplastic polyester
Terminals*	Brass
Moving blade	Brass
Spring	Stainless steel
Contacts F81, F82	Silver alloy
F83	Gold crosspoint
F84	Silver alloy/gold crosspoint

* Common terminals are plated – the remaining terminals are not plated.

Circuitry 2

Model	Code
Double pole S.P.S.T. - N.O.	A
Single pole S.P.S.T. - N.O. and single pole S.P.S.T. - N.C.	D
Single pole S.P.S.T. - N.O. and single pole S.P.D.T.	J*
Single pole S.P.S.T. - N.O.	X
Single pole S.P.S.T. - N.C.	Y
Single pole S.P.D.T.	Z

*only for F81 and F83

Housing 3

Model	Code
Basic case housing	A1
Button barrier housing	B1

Terminal type 5

Model	Code
Q.C. terminal 4.8 x 0.5 mm	10
Q.C. terminal 6.3 x 0.8 mm	20
Q.C. terminal 4.8 x 0.8 mm	40

Generation of order code (example)
The order code consists of 5 parameters:

1	2	3	4	5
Series	Electrical rating	Circuitry	Housing	Terminal type
F8 = Panel mount switch	2 = 16(6) A, 250 VAC	A = Double break	B1 = Button barrier housing	20 = Q.C. terminal 6.3 x 0.8

- Not every configurable variant is available for order. Please contact us.
- The final two digits of article numbers on commercial documents refer to the index of the respective drawing.
- Customer-specific models are marked with a G or W as the sixth digit of the article number.

Electrical rating and operating life 2

Electrical rating according to		Electrical life for 40T85 (operations)		Code
		acc. to EN	acc. to UL	
EN 61058-1	UL 1054			
10(3) A, 400 VAC	10 A, 125/250 VAC; 3/4HP, 125 VAC 1-1/2HP, 250 VAC; 6 A, 30 VDC	50,000	6,000	1
16(6) A, 250 VAC	16 A, 125/250 VAC; 3/4HP, 125 VAC 1-1/2HP, 250 VAC; 6 A, 30 VDC	50,000	6,000*	2
0.1(0.05) A, 250 VAC	0.1 A, 125/250 VAC	50,000	6,000*	3
on request	Combines two different ratings in a single switch. Available upon request.	50,000	6,000*	4

* Other ratings available upon request

Basic case housing

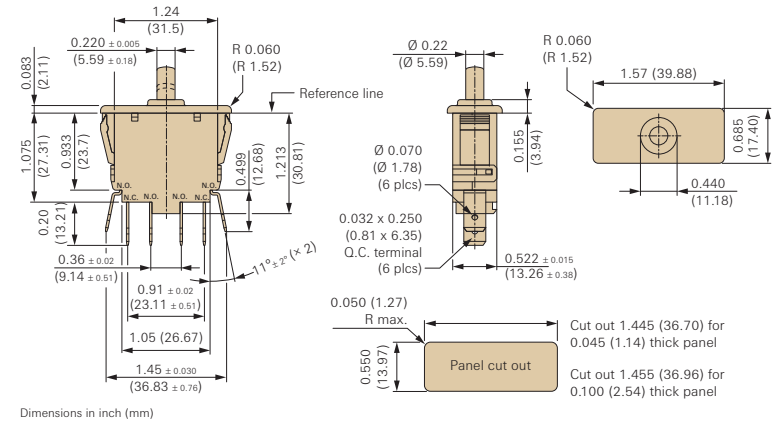

Button barrier housing

