

PANEL CUTOUT DETAIL  
RECOMMENDED  
PANEL THICKNESS  
.045-.100

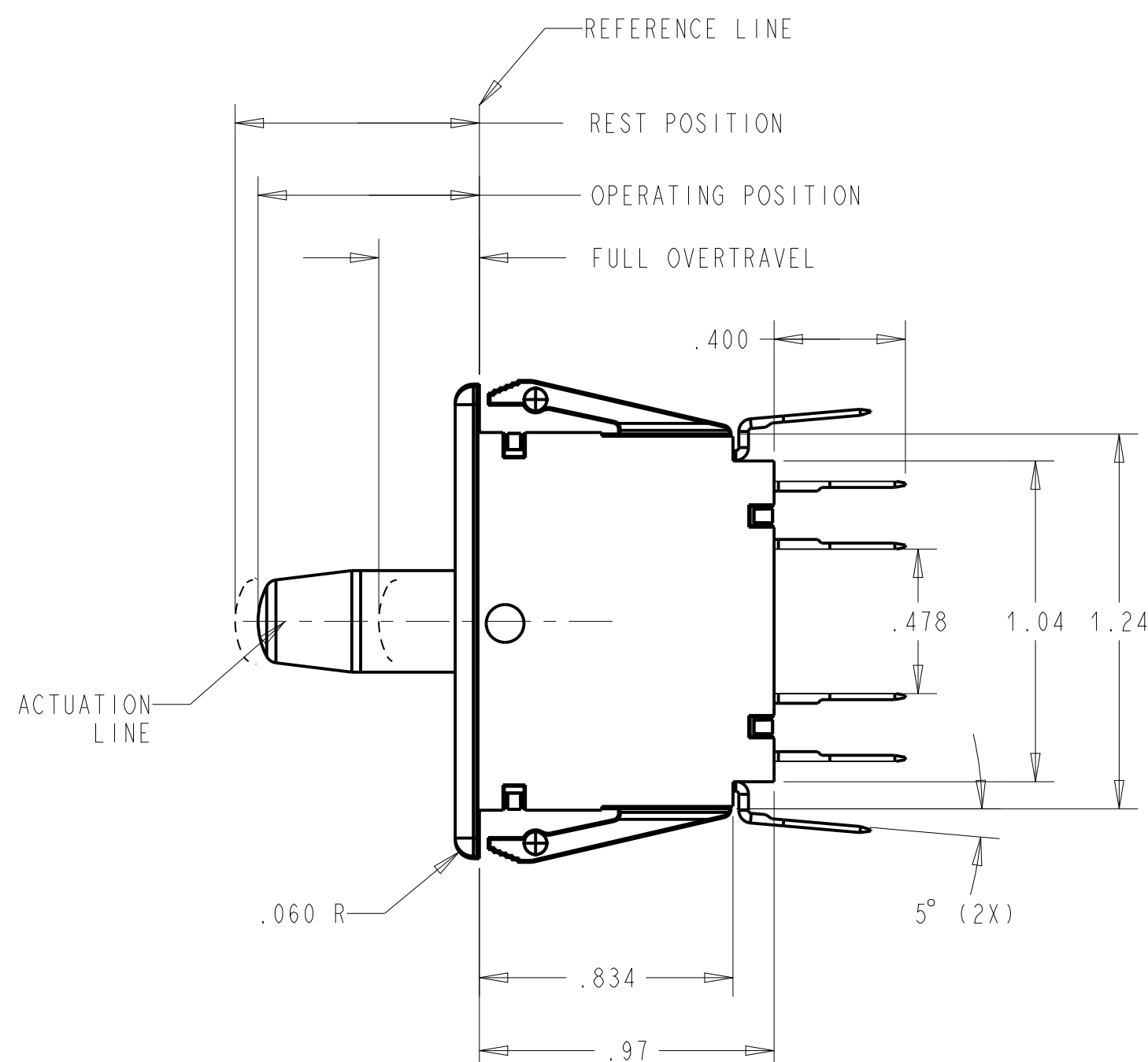
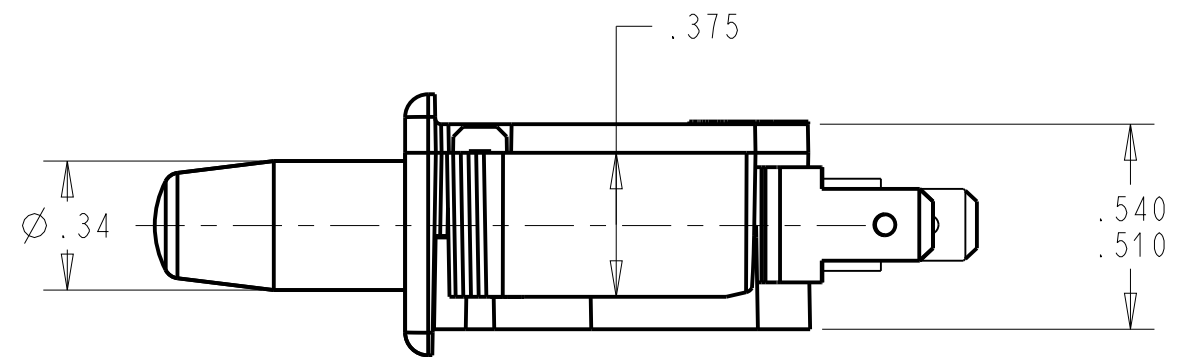
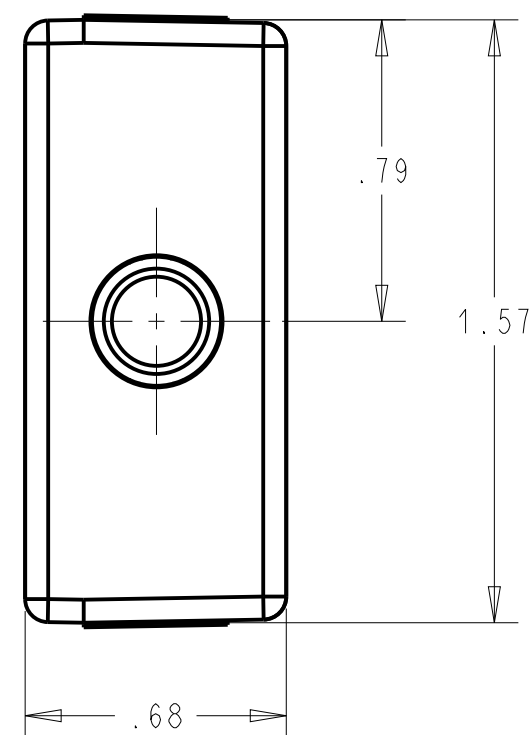

NOTES (UNLESS OTHERWISE SPECIFIED):

1. SWITCH CHARACTERISTICS:

REST POSITION:	.845 TO .905
PRETRAVEL:	.125 MAX.
OPERATING POSITION:	.720. TO .820
OVER-TRAVEL:	.375 MIN.
MOVEMENT DIFF:	.075 MAX.
OPERATING FORCE grams	680 MAX.
RELEASE FORCE grams	170 MIN.

BUTTON POSITION  
AT FULL OVERTRAVEL. .358 MAX.

ALL CHARACTERISTICS ARE TAKEN AT THE ACTUATION LINE AND MEASURED FROM THE REFERENCE LINE.

2. **UL** ELECTRICAL RATING:  
10 A, 125/250 VAC  
1/3 HP, 125/250 VAC.

**UL** 10(4) A 250V, 50E3, 40T85.

3. TERMINALS:  
ARE .187 WIDTH x .020 THICKNESS.

4. RECOGNIZED TO U.S. AND CANADIAN REQUIREMENTS  
UNDER THE COMPONENT RECOGNITION PROGRAM OF  
UNDERWRITERS LABORATORIES, INC.

5. TEMPERATURE RATING:  
-40°C TO +85°C

6. COLORS: FACEPLATE - WHITE  
BUTTON - WHITE

(C)

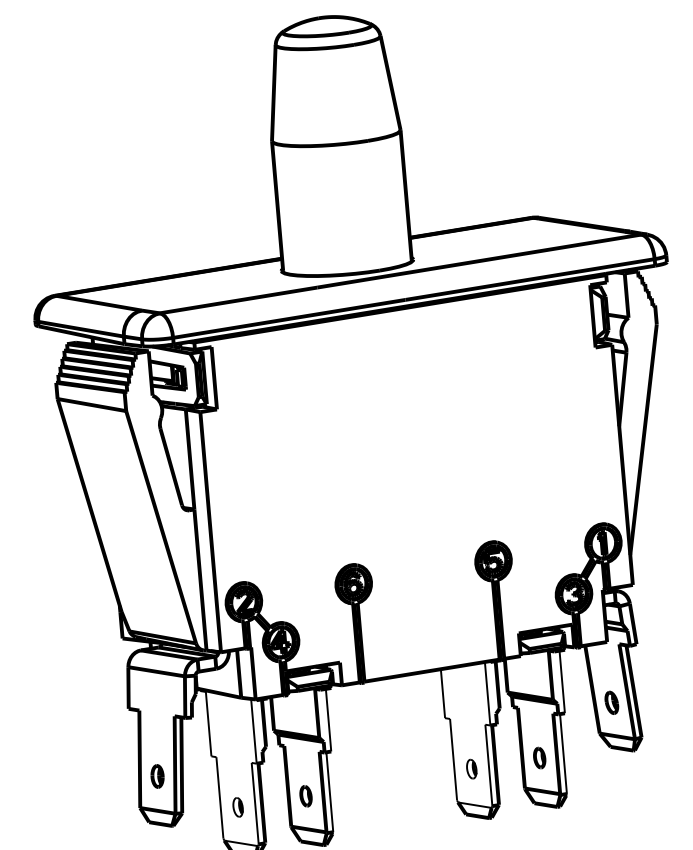

DWN: J. DOLNIK  
APVD: RC  
DATE: 28-Apr-03

THIRD ANGLE PROJECTION

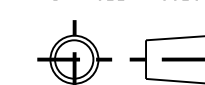

CONFIDENTIAL AND PROPRIETARY:  
ALL INFORMATION OR INVENTIONS CONTAINED IN THIS  
DOCUMENT OR DERIVED FROM THE INFORMATION THERE  
IN IS OWNED BY ZF ELECTRONIC SYSTEMS, AND IS  
CONFIDENTIAL AND PROPRIETARY. REVIEW OR  
POSSESSION OF THIS DOCUMENT INDICATES AGREEMENT  
THAT SUCH INFORMATION AND INVENTIONS WILL NOT BE  
DISCLOSED, REPRODUCED OR OTHERWISE USED IN ANY  
WAY WITHOUT EXPRESS WRITTEN PERMISSION FROM AN  
AUTHORIZED REPRESENTATIVE OF ZF ELECTRONIC  
SYSTEMS.



ZF Electronic Systems

11200 88th AVE. PLEASANT PRAIRIE, WI 53158

NAME / DESCRIPTION

SPECIFICATION DRAWING

C	Z000377659	6-Sept-16	TLM	ELL
REV	ECO NO.	DATE	PREP	APVD

PROJECT/ CSR	DWG UNITS	X.XX	X.XXX	ANGLES
4000000138	INCH	± 0.02	± 0.015	± 5.0 °

TOLERANCE UNLESS SPECIFIED
INCH ± 0.02 ± 0.015 ± 5.0 °

C	ITEM NO.	OF79-65A0
SCALE:	2.000	SH 1 OF 1

ORIGINAL ON PRO/E