

Gear Tooth Speed and Direction Sensor



SD501201 Sensors

Circuit protected, flange mount Hall Effect gear tooth speed and direction sensor

Description

The SD501201 has two Hall Effect sensors; one detects speed and the other detects direction of movement of gear teeth. The outputs are open collector transistors. Each Hall Effect sensor provides one square wave pulse output for each tooth. The Speed output goes low (ON) when detecting the leading edge of a tooth and high (OFF) on the trailing edge of the tooth when run against a standard target (see diagram). The Direction output goes low (ON) when detecting the leading edge of a tooth and high (OFF) at the trailing edge of the tooth. When the gear is rotating clockwise (as seen in diagram), the Direction output will lag the Speed output. When the gear is rotating counterclockwise (as seen in diagram), the Direction output leads the Speed output. An external pull-up resistor is required.

Features

- Immune to target run out
- Separate digital outputs for speed and direction
- From near zero speed up to 15 kHz sensing capability
- Plastic flange-mount sensor rated to 125 °C
- Compatible with unregulated power supply
- RoHS compliant
- IP67
- Typical air gap of 1.5 mm (0.06")*

Typical Applications

- Wheel speed and direction
- Hoist speed and direction
- Transmission speed and direction
- Industrial feedback and control

Environmental Specifications

Vibration	Sinusoidal, 3.3 g max from 20 Hz to 1 kHz
Maximum Speed Detection	15 kHz
Operating Temperature	-40 °C to 125 °C (-40 °F to 257 °F)
Storage Temperature	-40 °C to 125 °C (-40 °F to 257 °F)
Ingress Protection	IP67

Electrical Specifications

Operating Supply Voltage	5 to 24 VDC
Maximum Input Voltage	30 VDC
Maximum Reverse Voltage	30 VDC
Supply Current	8 mA typ., 12 mA max
Output Sink Current	25 mA max
Typical Operating Time	5 µs
Recommended Pull-Up Resistor	See chart

Mechanical Specifications

Housing Material	Glass Reinforced Thermoplastic
Maximum Installation Torque Limit	5.65 Nm (50 in lb) on threads
Operating Air Gap / Sensing Distance*	1.5 mm (0.06")
* With recommended target type; see drawing	
Sensor Orientation	Sensitive; see drawing

Products

Part Number	Connector**
SD501201	Delphi Metri-Pak 150

** Mates to Delphi 12162833 connector, 12124075 terminal

Note: An external pull-up resistor is required, the value of which is dependent on the supply voltage. The resistor should be connected between the output and Vcc. Refer to the wiring diagram for lead colors or pin numbering as applicable.



Recommended External Pull-Up Resistor

Volts DC	5	9	12	15	24
Ohms	1k	1.8k	2.4k	3k	4.8k

Open Collector Sinking Block Diagram

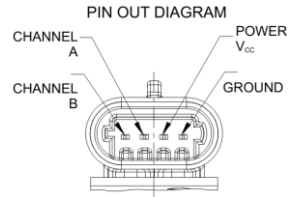
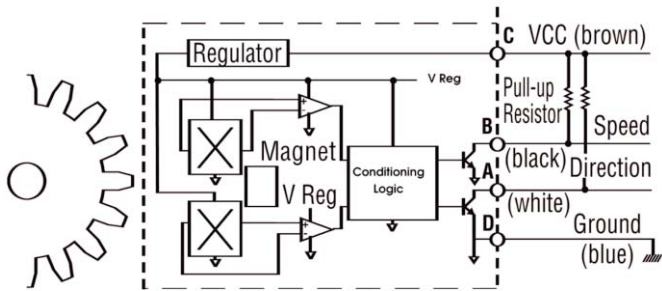

Dimensions mm (inches)

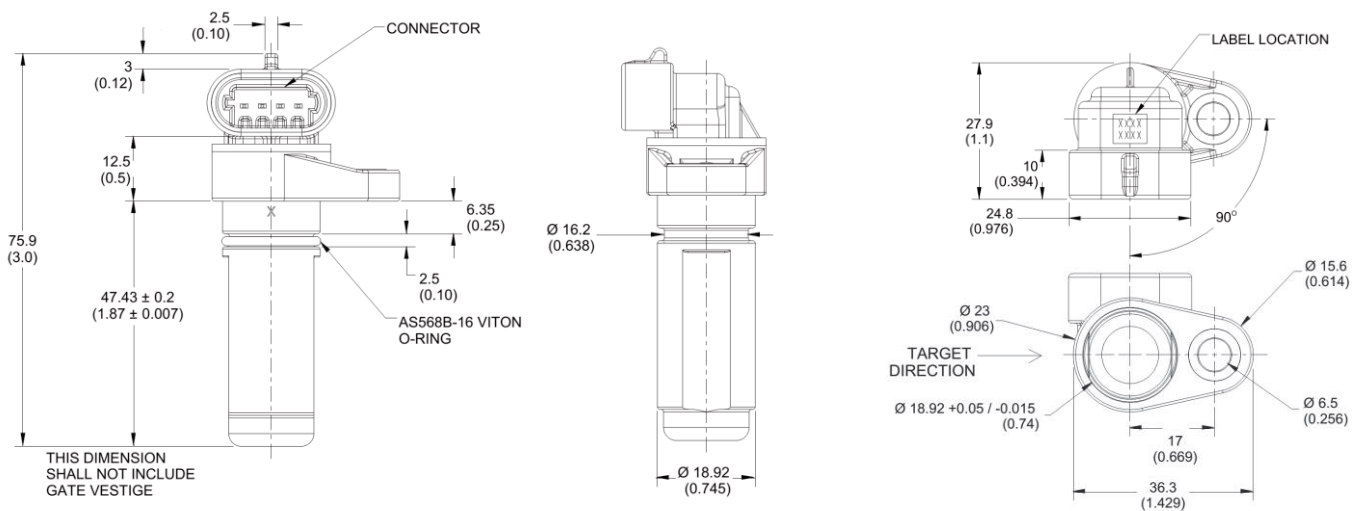

Installation

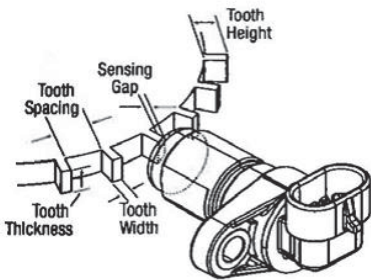

For best results, we recommend targets made from low carbon cold rolled steel. Other factors that influence sensor performance include gear tooth height and width, space between the teeth, shape of the teeth and thickness of the target. As a general guideline, consider a target with minimum parameters as shown below. Note that smaller dimensions may work, but testing for the application is required.

Tooth Height	Tooth Width	Distance between Teeth	Target Thickness
5.0 mm (.200")	2.5 mm (.100")	10 mm (.400")	6.35 mm (.250")