

# OPERATING AND INSTALLING THE LATCHING ENERGY HARVESTER

The energy harvester transforms mechanical energy into electrical energy. The operation and installation of the energy harvester are described here to enable you to implement it in your application.

## 1 Function

### 1.1 Actuating the generator

Inside the energy harvester is a generator, which consists of a coil and a magnet block.

When actuated in actuation direction 1 a mechanical force ( $F_1$ ) acts vertically on the end of the energy harvester's lever. A patented mechanism causes the magnetic block of the generator to move down abruptly (switching) and a positive pulse is created by reversing the polarity of the coil. When the lever is actuated in actuation direction 2, the system returns to the initial position (resetting) by means of the mechanism and a negative pulse is created.

The energy produced is used for transmitting a radio signal.

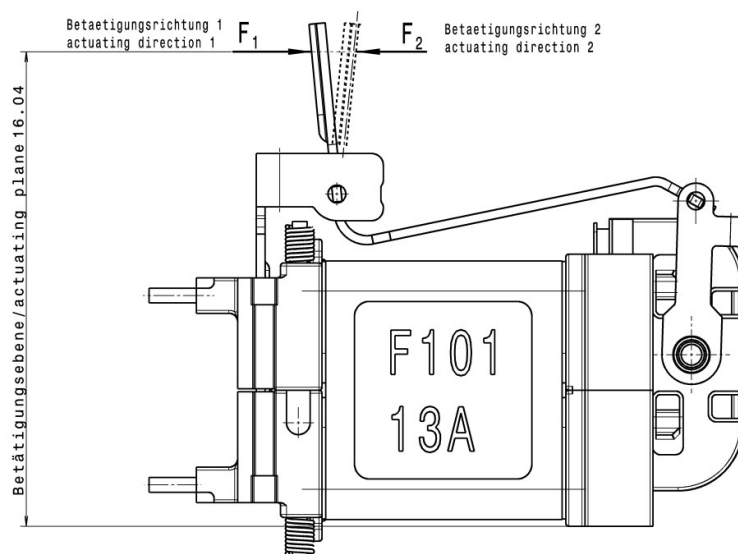

All dimensions in mm

Fig. 1 Actuating point

### 1.2 Force travel diagram

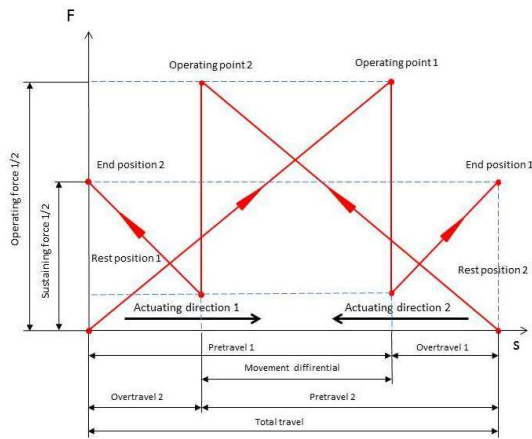

Fig. 2 Force travel diagram of the basic curve when actuating the energy harvester

### 1.3 Switching pulse

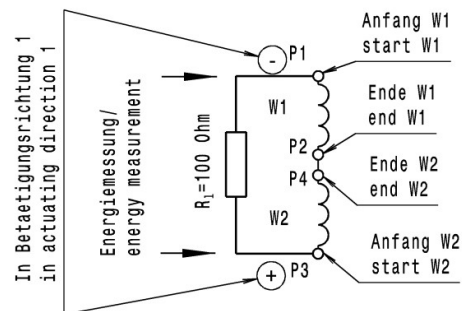

Fig. 3 Equivalent circuit diagram: Positive pulse when switching (W2) and negative pulse when resetting (W1).

## 1.4 Voltage time diagram

The following diagram shows the voltage curve of circuit at room temperature with a resistive load of  $100 \Omega$ .

Time-line: 1,000 samples corresponding to 10 msec.

Amplitude axis: Output voltage in volts

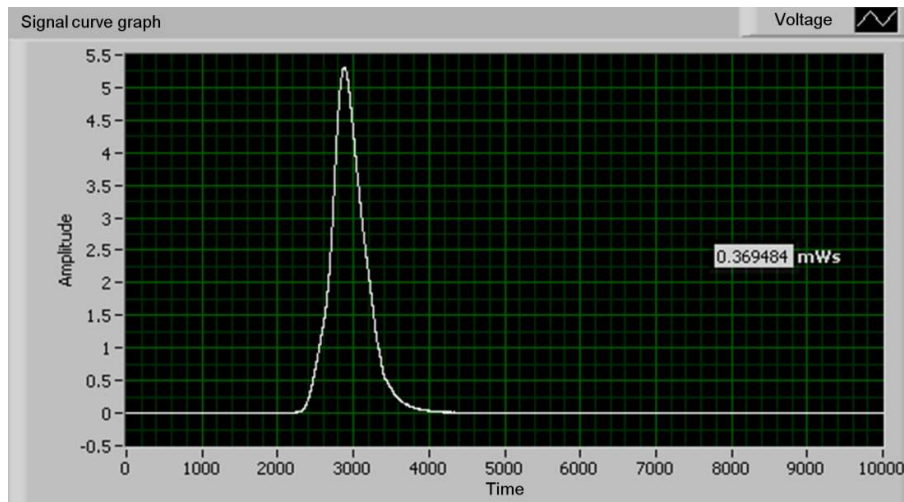

Fig. 4 Switching pulse

### 1.5 Impact of the ambient temperature

As the ambient temperature affects the conductivity of copper, the energy yield also changes accordingly. This means: when the ambient temperature drops, the energy yield increases and vice versa.

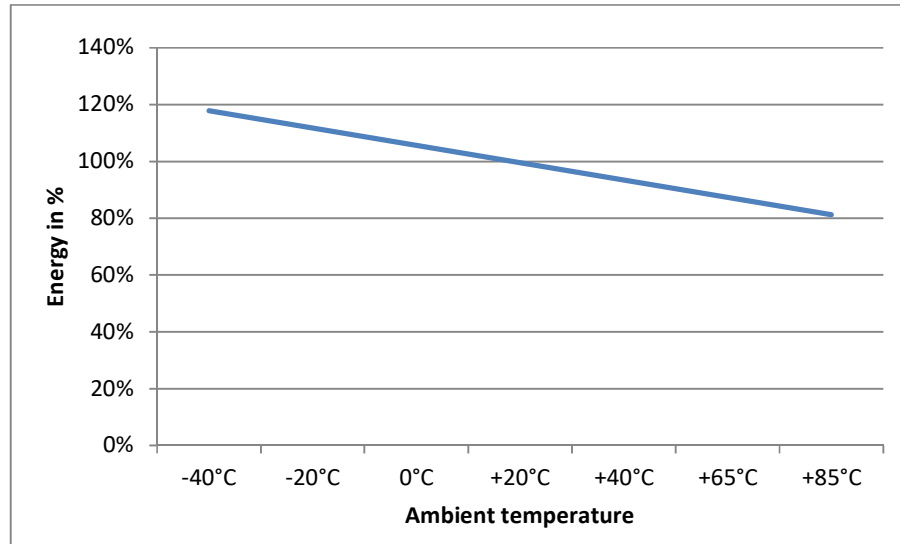

Fig. 5 Curve of the energy generated at different temperatures.  
Load = 100  $\Omega$  and actuating speed of 0.1 m/s.

### 1.6 Impact of the actuating speed

A higher actuation speed increases the energy yield, and reduces the service life of the energy harvester. You can ask for details at ZF Friedrichshafen AG, Electronic Systems.



Abb. 6 Example curve of the energy generated at different actuating speeds  
(at ambient temperature of 23 °C and a load of 100  $\Omega$ ).

## 2 Soldering

### 2.1 Contacting

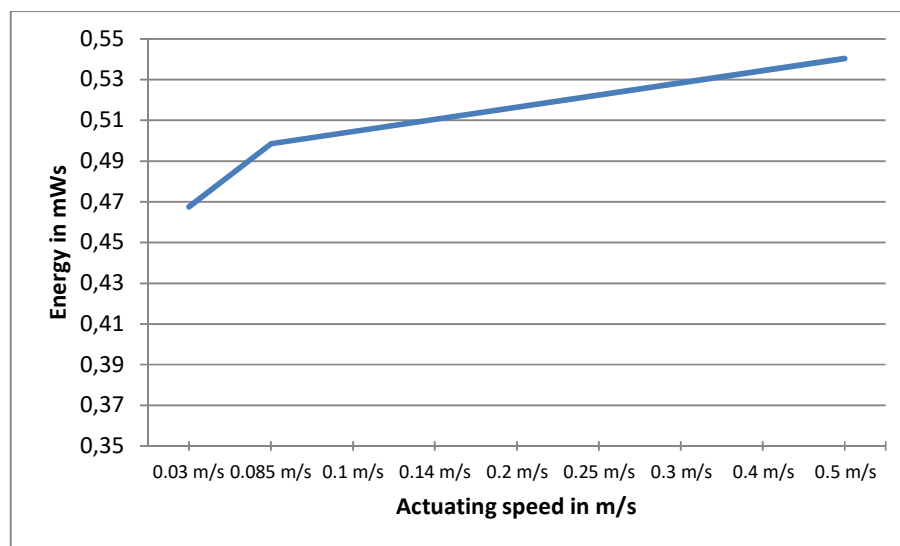
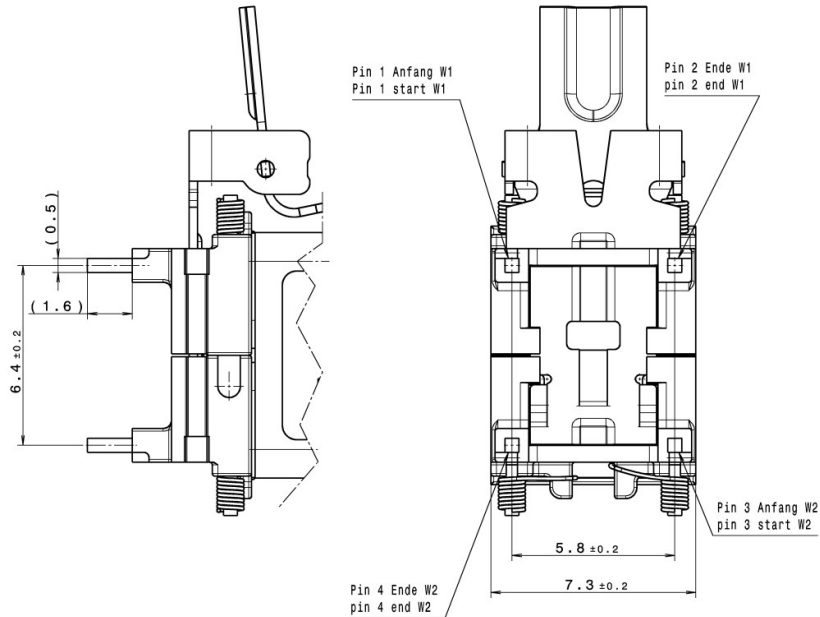

All dimensions in mm

Fig. 7 Pin assignment, see also equivalent circuit diagram, Fig. 3

### 2.2 Soldering notes

The energy harvester is designed for automatic soldering.

The following parameters for soldering with microdrop fluxing were specified by the supplier EBSO (EBSO 300 SPA 300 F, M00-0378):

Processing temperature	290 °C
Soldering time	2 sec
Solder	SAC305
Fluxing agent	Lonco RF 800

If you would like to use another soldering technique (e.g. hand soldering), please get in touch with ZF Friedrichshafen AG, Electronic Systems.

### 3 Installation instruction

#### 3.1 Physical dimensions of the energy harvester

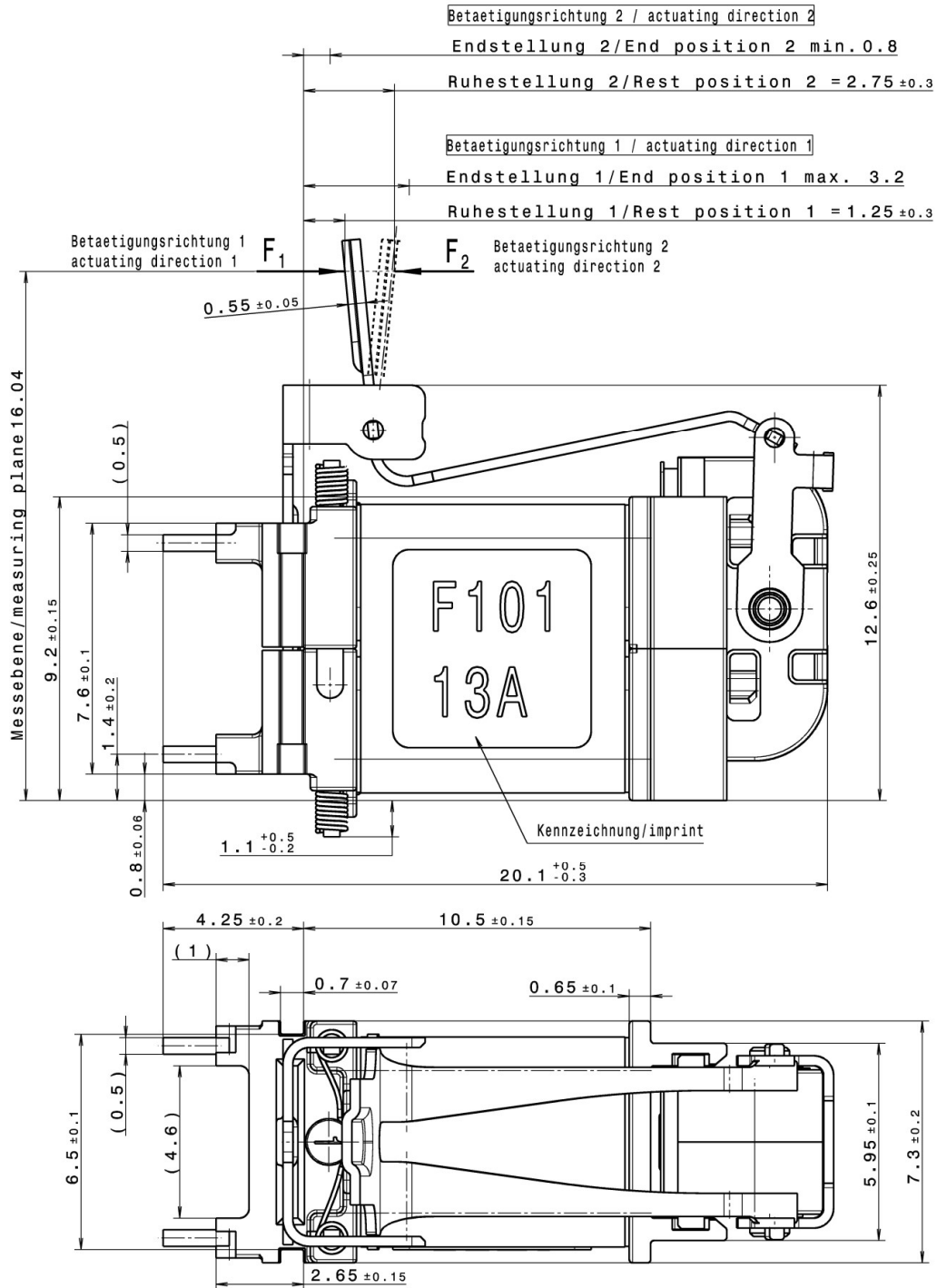

All dimensions in mm

Fig. 8 Energy harvester drawing

### 3.2 Dimensions with interface elements

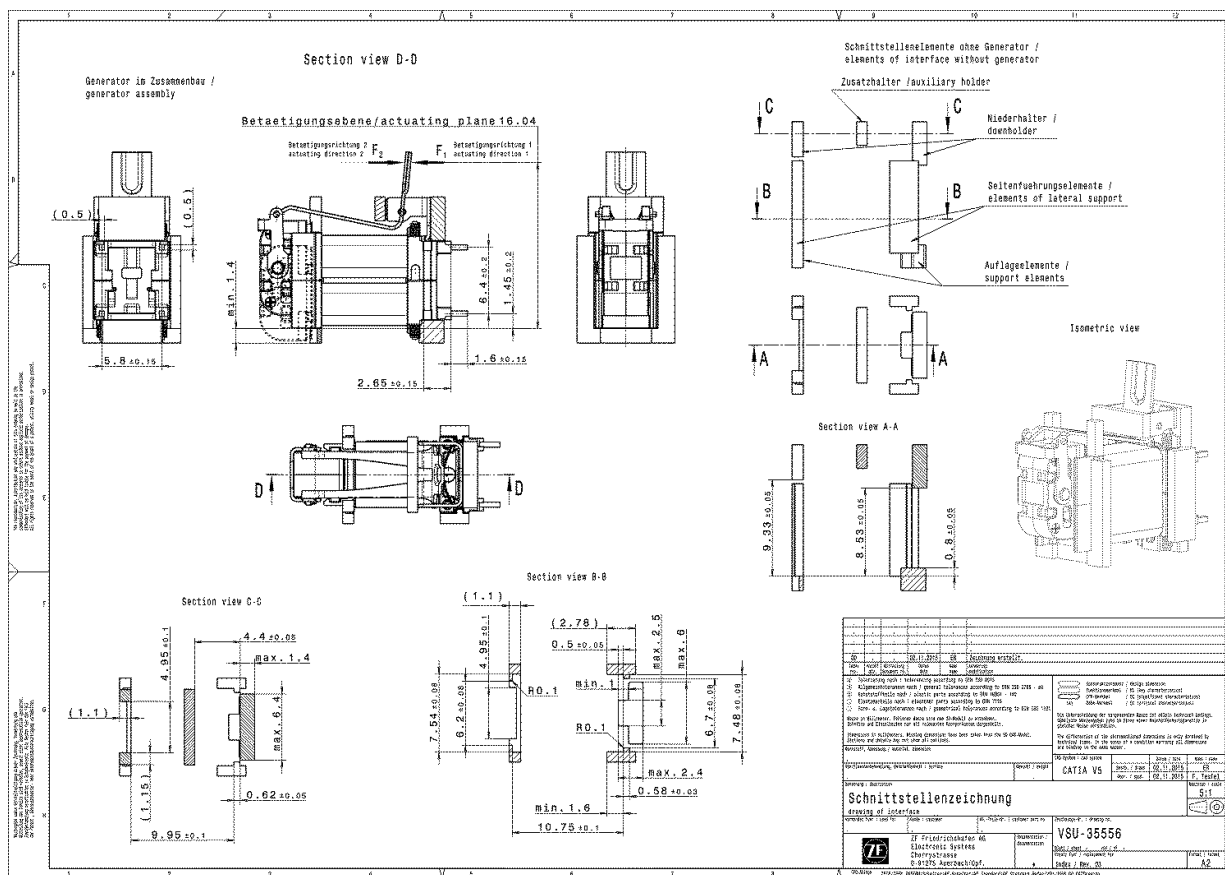

All dimensions in mm

Fig. 9 Interface elements drawing

We recommend to get in touch with ZF Friedrichshafen AG, Electronic Systems when using the generator only. You can also request the drawing from there.



### 3.3 Drilling pattern

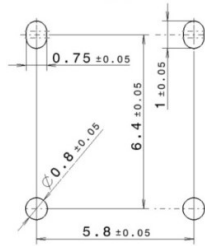

All dimensions in mm

Fig. 10 Drilling pattern

Europe:  
ZF Friedrichshafen AG  
Electronic Systems  
Graf-Zeppelin-Straße 1  
91275 Auerbach  
Germany

North America:  
ZF Electronic Systems  
Pleasant Prairie LLC  
11200 88th Avenue  
Pleasant Prairie, WI 53158  
USA

Asia-Pacific:  
ZF Electronics Asia Limited  
2/F Technology Plaza  
29-35 Sha Tsui Road  
Tsuen Wan, New Territories  
Hong Kong

Internet: [www.switches-sensors.zf.com](http://www.switches-sensors.zf.com)

E-Mail: [switches-sensors@zf.com](mailto:switches-sensors@zf.com)